

|  |           |                               |
|--|-----------|-------------------------------|
| Last Modified: 2-12-2007   |           | 1.6 A                         |
| Service Category: Vehicle Interior                                 |           | Section: Interior Panels/Trim |
| Model Year: 2008   | Model: xB | Doc ID: RM000001RHD005X       |
| Title: INSTRUMENT PANEL: UPPER INSTRUMENT PANEL: REMOVAL (2008 xB) |           |                               |

## REMOVAL

### 1. TABLE OF BOLT, SCREW AND NUT

#### HINT:

All bolts, screws and nuts relevant to installing and removing the instrument panel are shown along with their alphabet codes in the table below.

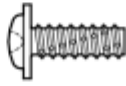
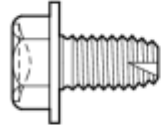
| mm(in.) (L=Length) |  |      |  |
|--------------------|--|------|--|
| Code               | Shape  | Code | Shape  |
| <A>                |  <p>φ=5<br/>(0.20)<br/>L=14<br/>(0.55)<br/>93568-55014</p> | <B>  |  <p>φ=8<br/>(0.31)<br/>L=15<br/>(0.59)<br/>90105-08120</p> |

### 2. DISCONNECT CABLE FROM NEGATIVE BATTERY TERMINAL

#### CAUTION:

Wait at least 90 seconds after disconnecting the cable to prevent the airbag working.

### 3. SEPARATE FRONT DOOR OPENING TRIM WEATHERSTRIP RH

- (a) Separate the front door opening trim weatherstrip RH.

### 4. SEPARATE FRONT DOOR OPENING TRIM WEATHERSTRIP LH

- (a) Separate the front door opening trim weatherstrip LH.

### 5. REMOVE FRONT PILLAR GARNISH RH

INFO

### 6. REMOVE FRONT PILLAR GARNISH LH

INFO

### 7. REMOVE INSTRUMENT CLUSTER FINISH CENTER PANEL SUB-ASSEMBLY

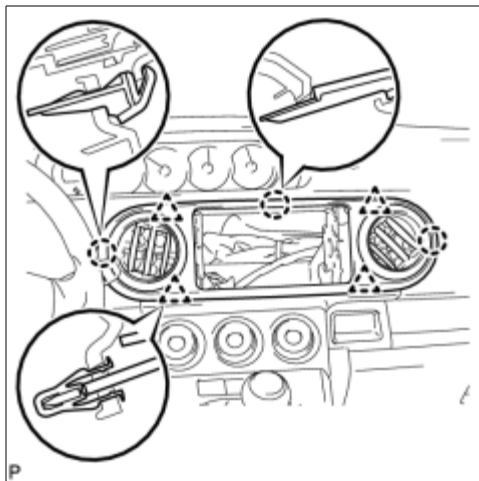

(a) Disengage the 4 clips, 3 claws and remove the instrument cluster finish center panel.

#### 8. REMOVE NO. 4 INSTRUMENT PANEL REGISTER ASSEMBLY

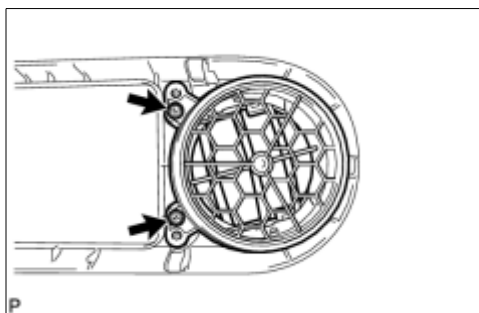

(a) Remove the 2 <A> screws and remove the instrument panel register.

#### 9. REMOVE INSTRUMENT CLUSTER FINISH LOWER PANEL

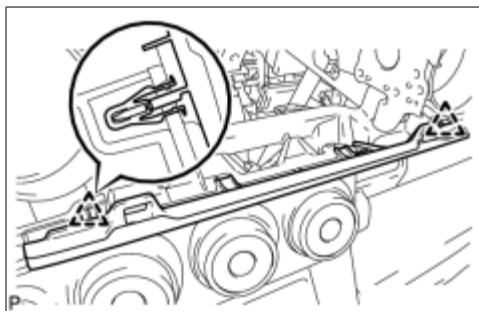

(a) Disengage the 2 clips and remove the instrument cluster finish lower panel.

#### 10. REMOVE INSTRUMENT CLUSTER FINISH PANEL ASSEMBLY

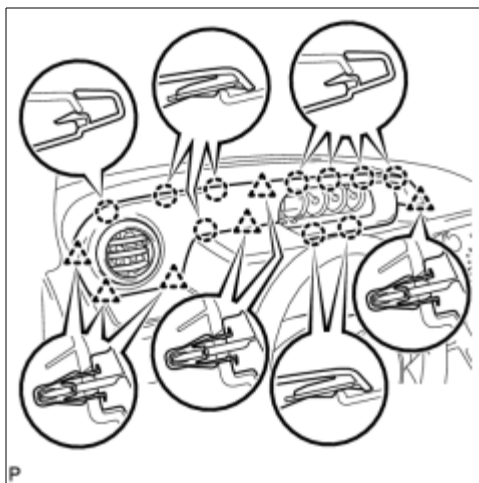

(a) Disengage the 6 clips, 10 claws and remove the instrument cluster finish panel.

**11. REMOVE NO. 4 INSTRUMENT PANEL REGISTER ASSEMBLY**

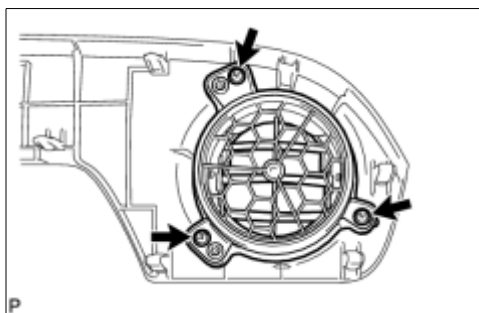

(a) Remove the 3 <A> screws and remove the instrument panel register.

**12. REMOVE COMBINATION METER ASSEMBLY** INFO

**13. REMOVE GLOVE COMPARTMENT DOOR ASSEMBLY**

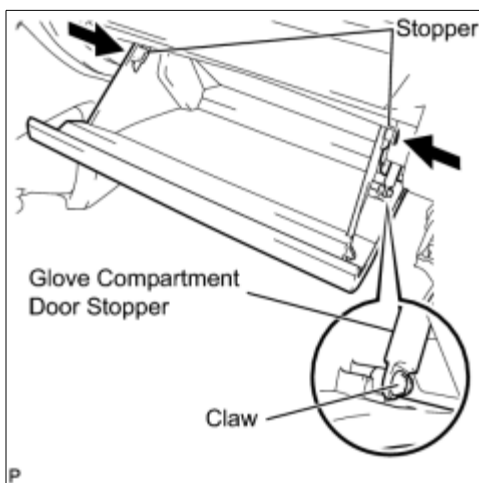

(a) Disengage the claw and disconnect the glove compartment door stopper.

(b) Slightly flex the upper part of the glove compartment door to release the 2 stoppers and open the glove compartment door until it becomes horizontal.

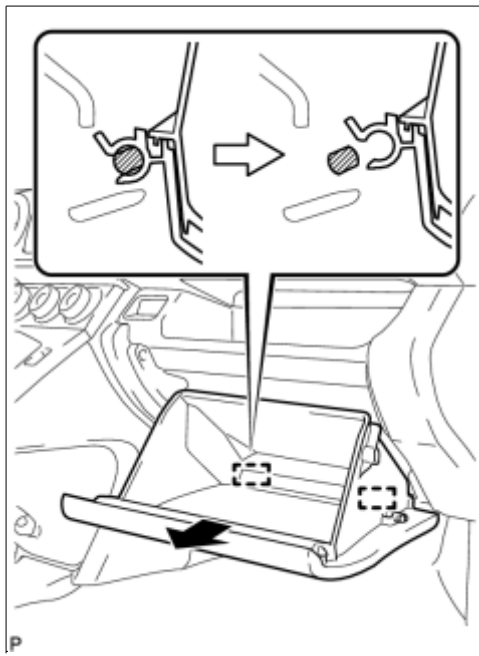

(c) Pull the glove compartment door out horizontally to disengage the 2 hinges and remove the glove compartment door.

**NOTICE:**

**Pull the glove compartment door out horizontally, otherwise, installation failure caused by excessive play around the hinge will result.**

**14. REMOVE UPPER INSTRUMENT PANEL SUB-ASSEMBLY**

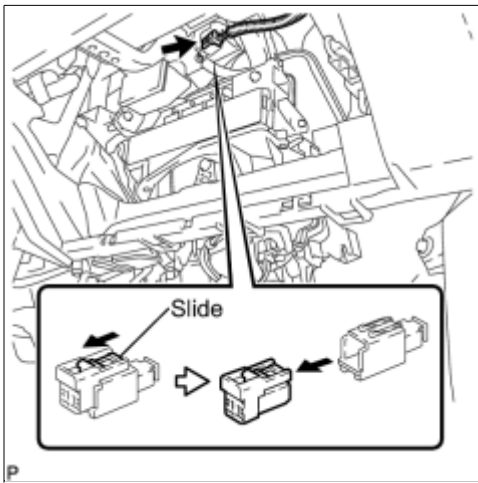

- (a) Slide the slider and disconnect the airbag connector.
- (b) Using a clip remover, remove the airbag connector.
- (c) Remove the <B> bolt and 3 <A> screws.

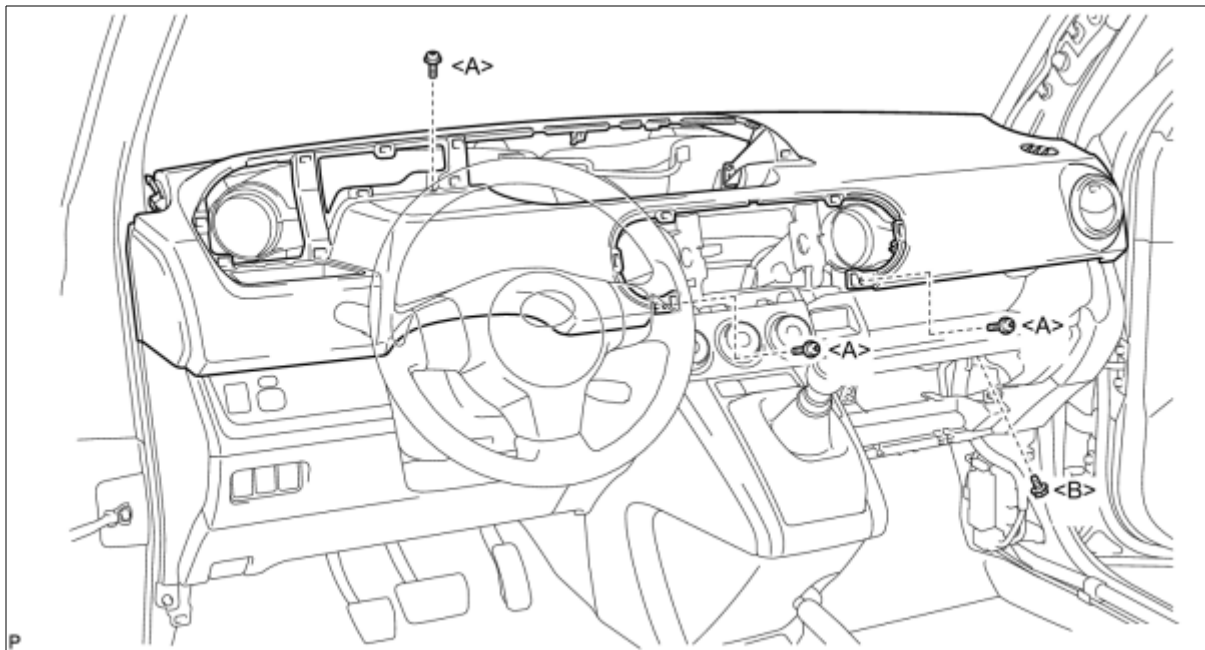

(d) Disengage the 2 clips and 4 claws by lifting the rear side of the upper instrument panel up.

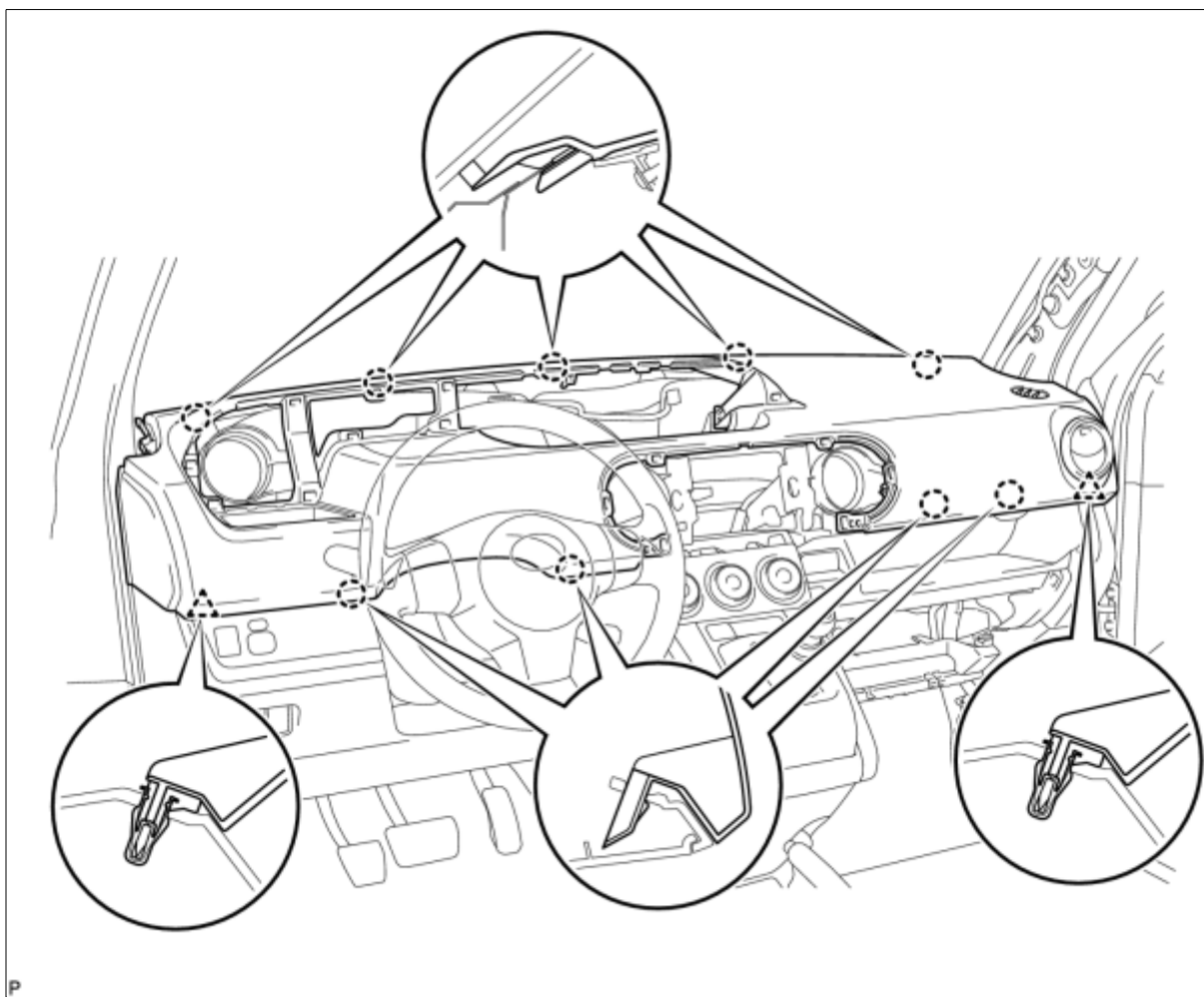

(e) While lifting the upper instrument panel, slide it toward the rear of the vehicle. Disengage the 5 claws from the front side of the upper instrument panel and remove the upper instrument panel.

### 15. REMOVE DEFROSTER NOZZLE ASSEMBLY

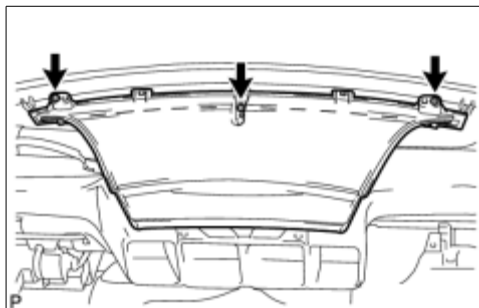

(a) Remove the 3 <A> screws and remove the defroster nozzle.

### 16. REMOVE NO. 2 HEATER TO REGISTER DUCT SUB-ASSEMBLY

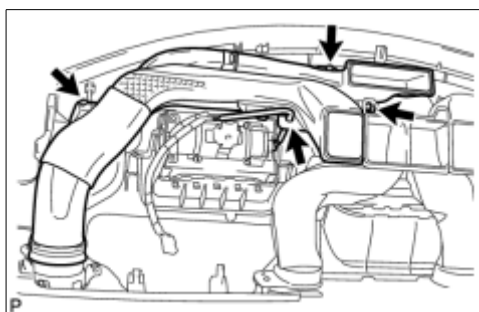

(a) Separate the airbag wire harness.

(b) Remove the 3 <A> screws and remove the heater to register duct

### 17. REMOVE NO. 1 HEATER TO REGISTER DUCT

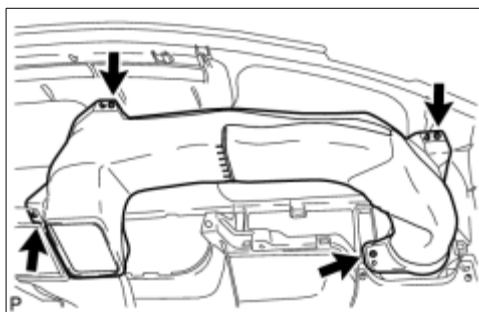

(a) Remove the 4 <A> screws and remove the heater to register duct.

### 18. REMOVE NO. 2 HEATER TO REGISTER DUCT

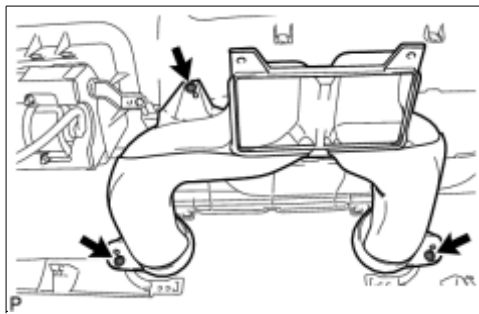

(a) Remove the 3 <A> screws and remove the heater to register duct.

#### 19. REMOVE NO. 4 INSTRUMENT PANEL REGISTER ASSEMBLY

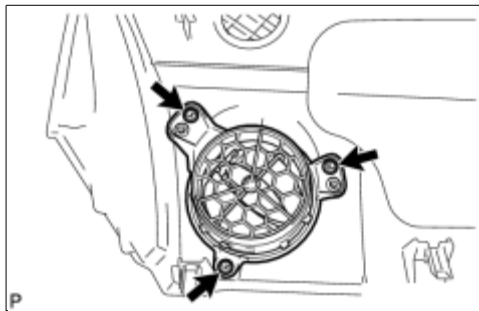

(a) Remove the 3 <A> screws and remove the instrument panel register.

#### 20. REMOVE NO. 1 INSTRUMENT PANEL BOX

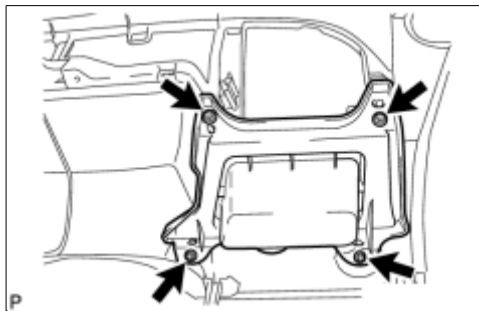

(a) Remove the 4 <A> screws and remove the instrument panel box.

#### 21. REMOVE NO. 1 INSTRUMENT PANEL CUSHION

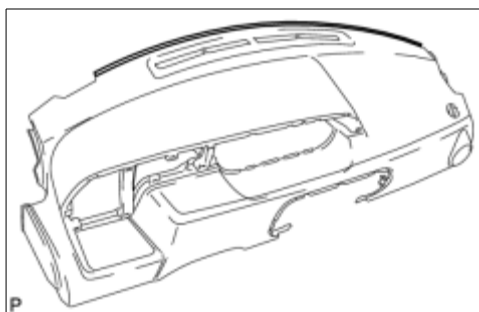

(a) Remove the instrument panel cushion.

#### 22. REMOVE NO. 2 INSTRUMENT PANEL CUSHION

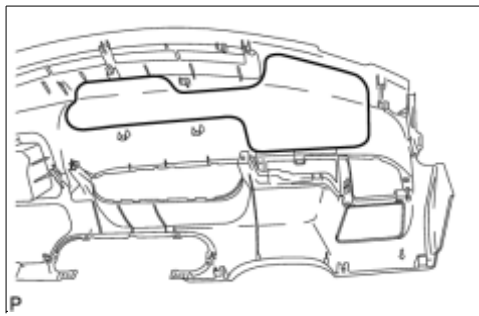

(a) Remove the instrument panel cushion.

### 23. REMOVE NO. 3 INSTRUMENT PANEL CUSHION

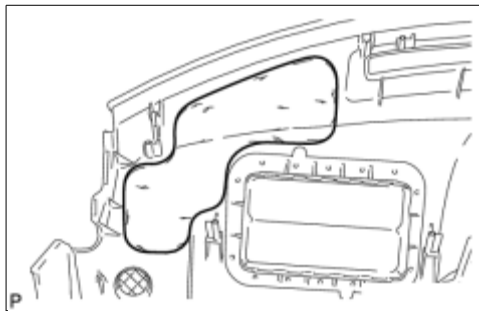

(a) Remove the instrument panel cushion.

### 24. REMOVE NO. 4 INSTRUMENT PANEL CUSHION

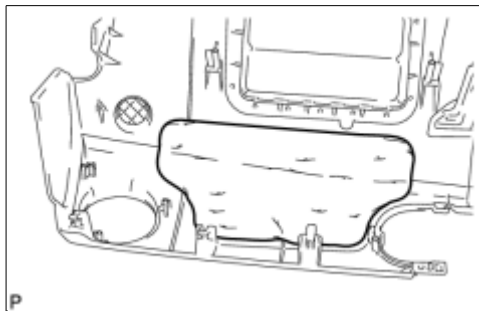

(a) Remove the instrument panel cushion.

### 25. REMOVE FRONT PASSENGER AIR BAG ASSEMBLY

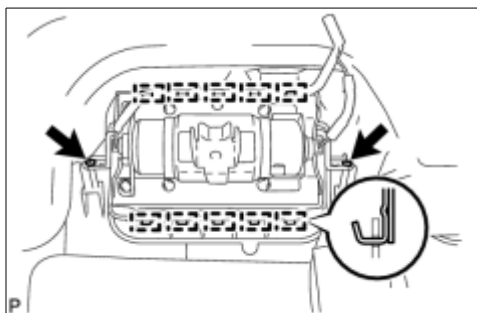

(a) Remove the 2 screws.

(b) Disengage the 10 hooks and remove the front passenger airbag.

